

RESILENT GATE VALVE PN16

Typ 180



ISO 9001 : 2008

CSICERT



WRAS
APPROVED
PRODUCT

Size : DN 40 to DN 300
Ends : ISO PN10/16 flanges
Min Temperature : - 10°C
Max Temperature : + 120°C
Max Pressure : 16 Bars
Specifications : Non rising stem
Counterclockwise to close
Full and total bore

Materials : Ductile iron body

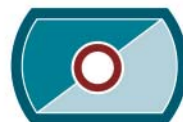

RESILENT GATE VALVE PN16

Typ 180

SPECIFICATIONS :

- Full and total bore
- Stainless steel non rising stem
- Counterclockwise to close
- Ductile iron wedge EPDM coated
- No retention area
- Heel positioning
- NBR bonnet gasket
- Screws bonnet protected
- 3 NBR O ring on stem
- Possibility to change stem gasket under pressure
- Epoxy painting RAL 5005 color 250 µm thickness
- Dust-coat on stem
- ISO PN10/16 flanges R.F.

USE :

- For water distribution
- Min and max Temperature Ts : - 10°C to + 120°C
- Max Pressure PN : 16 bars

RANGE :

- Ductile iron body with ISO PN10/16 flanges R.F. and handwheel **Ref. 180** from DN 40 to DN 300
- Possible with cap top (option) **Ref. 9801831-9801834**



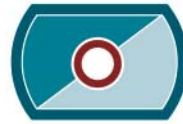

RESILENT GATE VALVE PN16

Typ 180

MATERIALS :

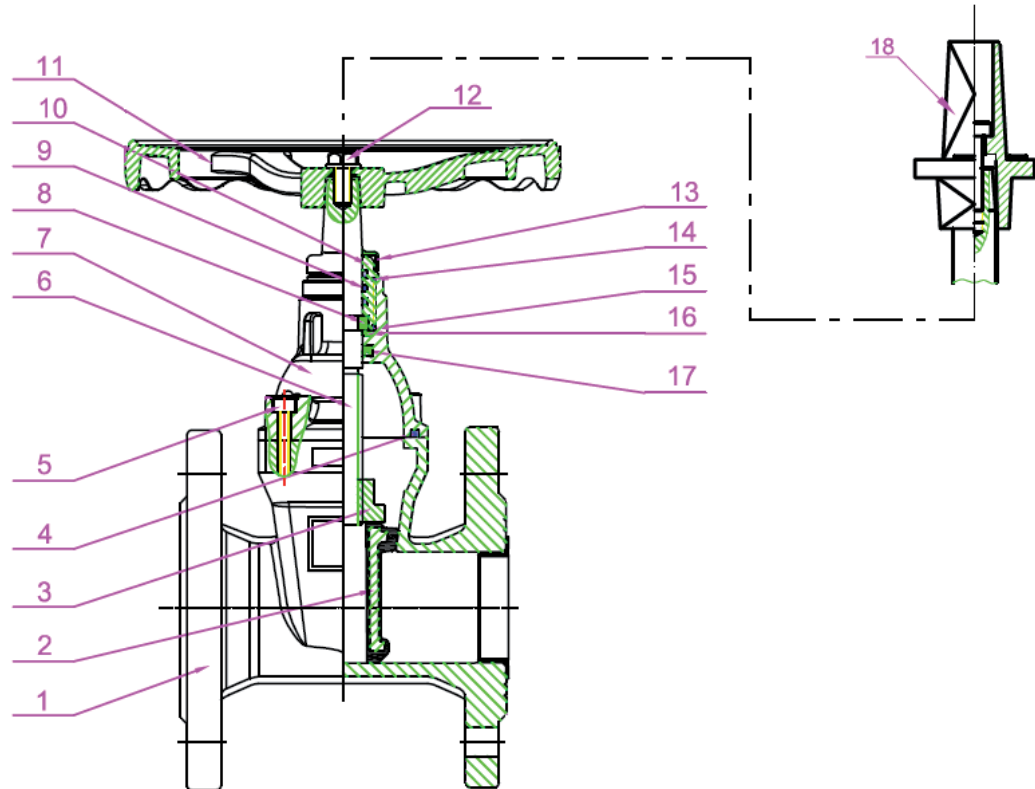

Item	Designation	Materials
1	Body	Ductile iron EN GJS-500-7
2	Wedge	Ductile iron EN GJS-500-7 + EPDM
3	Stem nut	Brass CuZn39Pb2
4	Gasket bonnet	NBR
5	Bonnet screw	Steel C35
6	Stem	SS 420
7	Bonnet	Ductile iron EN GJS-500-7
8	Holding ring	Brass CuZn39Pb2
9	O ring	NBR
10	Pusher nut	Brass CuZn39Pb2
11	Handwheel	Ductile iron EN GJS-500-7
12	Handwheel screw	Steel Rst 37-2
13	Dust-coat	NBR
14	O ring	NBR
15	O ring	NBR
16	Ring	Nylon 66
17	Auto sealing ring	NBR
18	Cap top	Ductile iron EN GJS-500-7

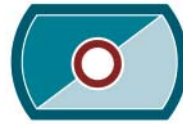

RESILENT GATE VALVE PN16

Typ 180

HANDWHEEL VALVE SIZE (in mm) :

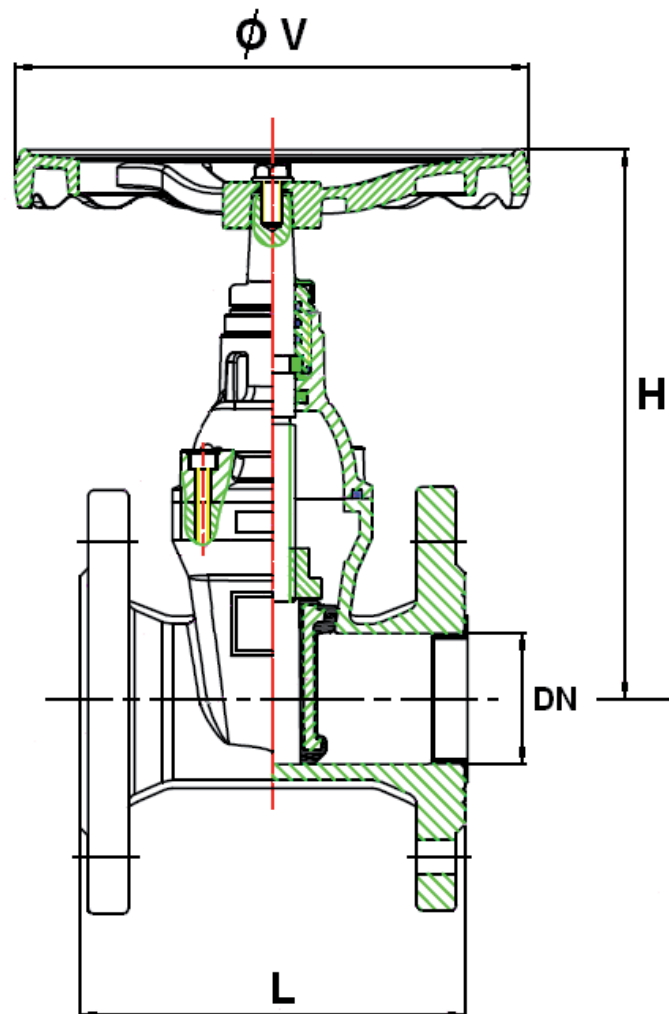

Ref.	DN	40	50	65	80	100	125	150	200	250	300
180	L	140	150	170	180	190	200	210	230	250	270
	H	190	215	235	265	315	350	385	485	600	680
	Ø V	200	200	200	254	254	315	315	315	406	406
	Weight (Kg)	7.38	8.83	12.12	13.32	19.65	23.12	32.08	53.9	79.39	107.31



RESILIENT GATE VALVE PN16

Typ 180

CAP TOP VALVE SIZE (in mm) :

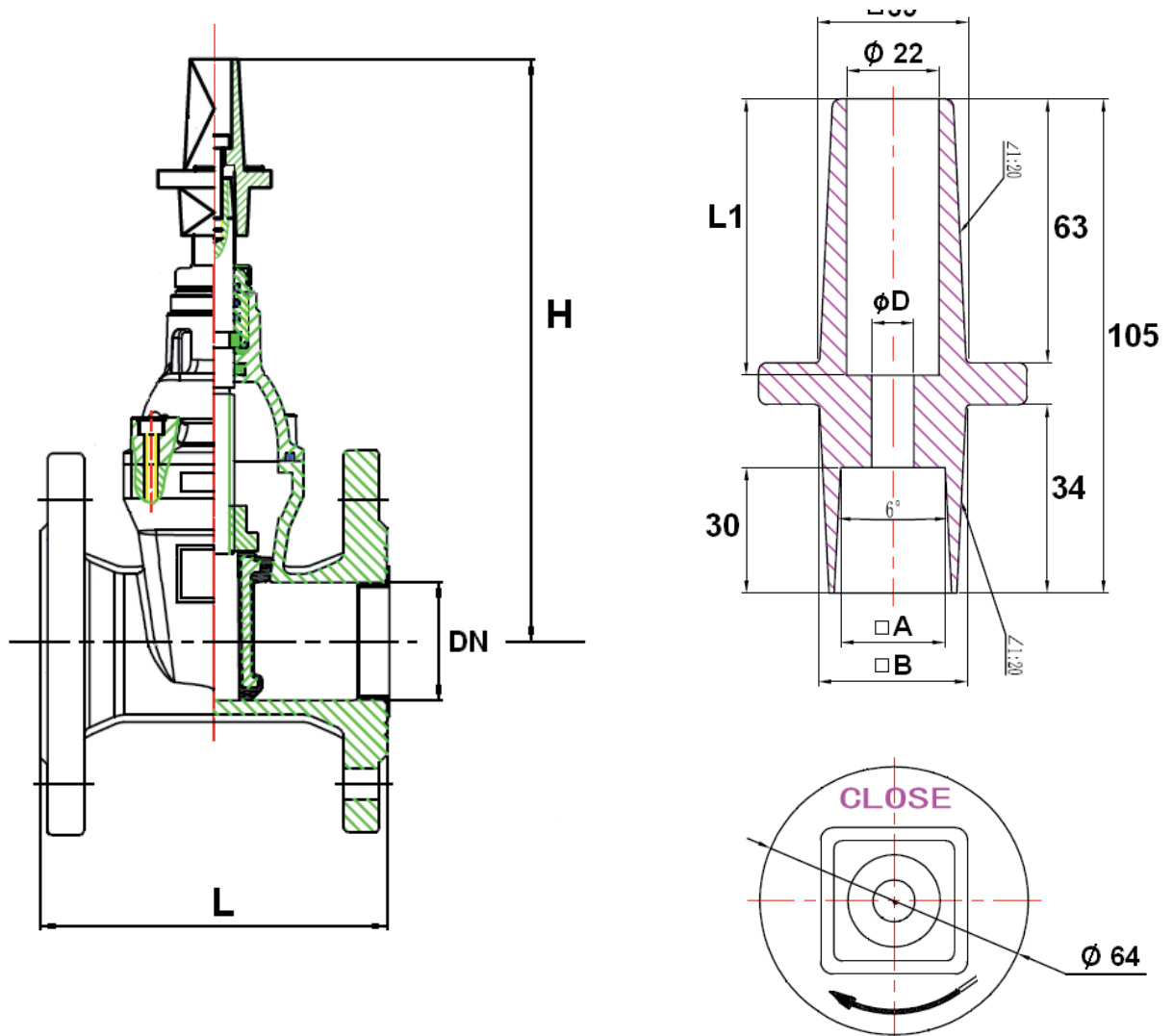

Ref.	DN	40	50	65	80	100	125	150	200	250	300
180 + 9801831-34	L	140	150	170	180	190	200	210	230	250	270
	H	280	285	300	320	390	430	470	560	680	770
	A	14	14	14	17	17	19	19	19	24	24
	B	34	34	34	34	34	36	36	36	42.5	42.5
	L1	66	66	66	63	63	63	63	63	63	63
	Ø D	10	10	10	10	10	10	10	10	12	12
	Weight (Kg)	6.93	8.38	11.12	12.22	18.01	21.48	30.44	50.56	74.98	102.9

TORQUE VALUES (in Nm without safety coefficient) :

DN	40	50	65	80	100	125	150	200	250	300
Torque (Nm)	35	40	45	50	55	70	75	100	160	245

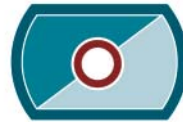

RESILENT GATE VALVE PN16

Typ 180

INSTALLATION INSTRUCTIONS

GENERAL GUIDELINES :

- Ensure that the valves to be used are appropriate for the conditions of the installation (type of fluid, pressure and temperature).
- Be sure to have enough valves to be able to isolate the sections of piping as well as the appropriate equipment for maintenance and repair.
- Ensure that the valves to be installed are of correct strength to be able to support the capacity of their usage.
- **Installation of all circuits should ensure that their function can be automatically tested on a regular basis (at least two times a year).**

INSTALLATION INSTRUCTIONS :

- **Before installing the valves, clean and remove any objects from the pipes** (in particular bits of sealing and metal) which could obstruct and block the valves.
- **Ensure that both connecting pipes either side of the valve (upstream and downstream) are aligned (if they're not, the valves may not work correctly).**
- **Make sure that the two sections of the pipe (upstream and downstream) match, the valve unit will not absorb any gaps. Any distortions in the pipes may affect the tightness of the connection, the working of the valve and can even cause a rupture.** To be sure, place the kit in position to ensure the assembling will work.
- **If sections of piping do not have their final support in place, they should be temporarily fixed. This is to avoid unnecessary strain on the valve.**
- Tighten the bolts in cross.
- It's recommended to operate the valve (open and close) 1 to 2 times per year