

Typ ATHENA

FLOAT VALVE

PN 16, with balance single seat

Thanks to its exclusive technology ATHENA brings the concept of reliability and performance to the highest standards, also because of its 3 ways body it can be used with an angle or globe pattern making it suitable for every installation.

Designed according to ISO 5752 series 1 or DIN 3202 F1 provisions.

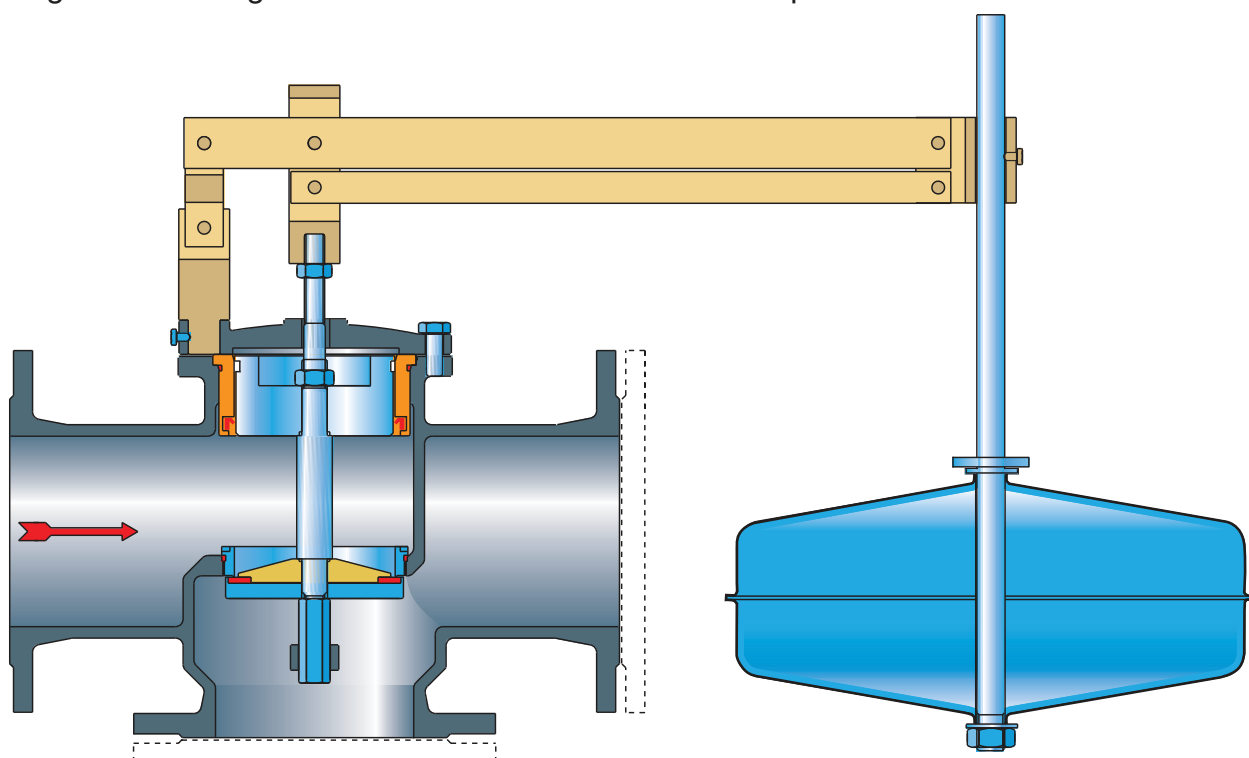

Design features

Athena is composed of:

- Body in GS400-15 with **3 ways PN 16 flanges**, allowing the installation both in a vertical and a horizontal position, containing an interchangeable sealing seat in stainless steel and a piston sliding bush in bronze.
- Cover in carbon steel or GS400-15 containing the float lever's fixed pivot.
- Mobile block containing the main shaft, holding the obturator in stainless steel as well as the gasket retainer and piston in brass.
- The lever mechanism is made out of a double rod in rolled steel (single for DN 50/65) which, by means of stainless steel pivots, puts in communication the main shaft with the float which is leading the movement allowing the opening or closing of the valve.
- A large float in stainless steel AISI 304 is connected to the above mentioned rods by a stainless steel pipe, which is exerting a vertical force onto.

* Gasket retainer for progressive flow rate as an option

Working conditions

- Max temperature 70°C
- Max pressure PN 16 (please contact us for higher values)
- Flanged PN 16 according to UNI EN 545 standard.
- Max Dp suggested 8bar.



Typ ATHENA

FLOAT VALVE

PN 16, with balance single seat

Operating principle

Flanged to the incoming pipe and driven by a large float in stainless steel, the valve will automatically control the water level inside the tank by cutting off the supply whenever it reaches the maximum level to reopen again as soon as it drops.

Main benefits

The ATHENA design has helped us obtain a **perfectly balanced valve** because the upstream pressure is acting both on the piston and the obturator, whose surface is the same, yielding two forces equal in magnitude but in opposite directions and therefore annulling each other. The valve is only driven by the movement of the float which, thanks to the double rods lever mechanism, leads the main shaft.

The internal cross sections have been designed in order to have a reduced passage to allow the discharge of large volume of water yet avoiding any sudden drop in pressure facilitating the opening of the valve itself.

The main benefits are:

- **High sensitivity**, perfect water tightness even with low pressure values;
- **Progressive movement of the obturator during opening and closing**, that means transients effects are avoided;
- Excellent performance with low roughness coefficients and reduced maintenance;
- Working conditions that could engender lamination are avoided by using a gradual flow rate gasket retainer;

Maximum flow rate

Purely as an indication the maximum flow rate (for angle pattern) as follows:

DN	40	50	65	80	100	125	150	200	250
l/s	2,9	2,9	6,7	10	15,5	24	38	70	75

Standard version:

The rod is aligned with the axis itself. It is possible to change the position of the rod within an angle of 45°.

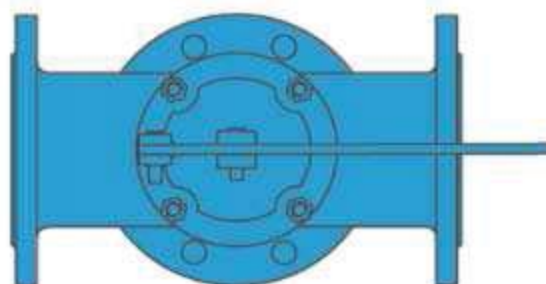

Version supplied on request:

The rod is positioned with an angle of 45° on the valves axis in order not to hinder installation in horizontal position. It is possible to change the position of the rod further within 45°.

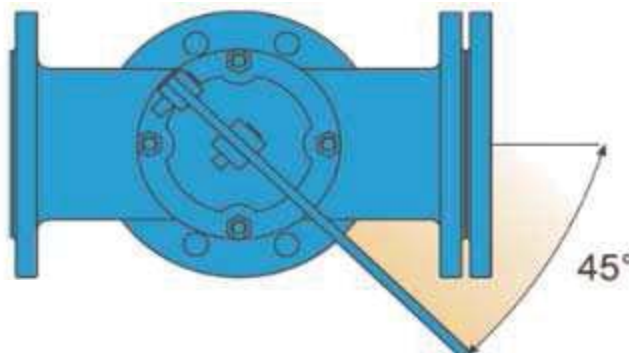

Testing

Every single piece undergo two tests:

- The body's resistance with a pressure of 24 bar
- The obturator's resistance with a pressure of 18 bar

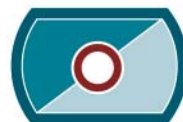

Typ ATHENA

FLOAT VALVE

PN 16, with balance single seat

Technical features

Body in GS 400-15 FBE coated with fluidized bed technology

Cover in carbon steel or GS400-15 FBE coated with fluidized bed technology

Obturator block in stainless steel

Sealing seat in stainless steel

Piston and shaft in brass/stainless steel

Float in stainless steel

Rods and joints in rolled steel

Bolts and pivots in stainless steel A2

Gaskets in NBR-Polyurethane

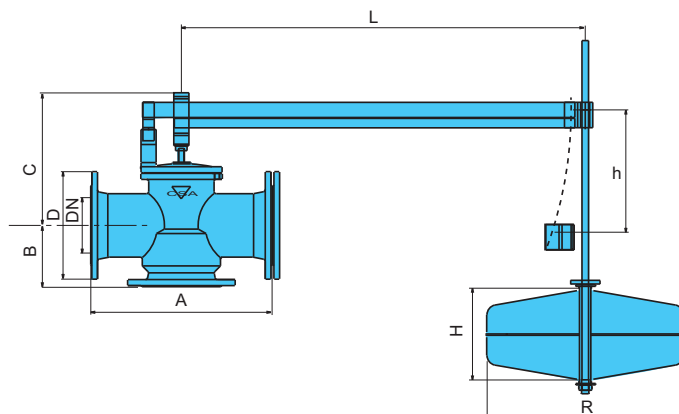

DN	A	B	C	D	L	H	R	Weight
(mm)	(mm)	(mm)	(mm)	(mm)	(mm)	(mm)	(mm)	(Kg)
40	230	82,5	173	165	600	200	300	21,0
50	230	82,5	173	165	600	200	300	21,0
65	290	92,5	193	185	600	200	300	25,6
80	310	100	212	200	800	180	400	32,6
100	350	125	225	220	800	180	400	41,0
125	400	125	230	250	800	180	400	49,0
150	480	162	351	285	1000	250	400	78,5
200	600	183	380	340	1000	250	400	118,0
250	600	200	380	405	1000	300	500	138,0

*New painting process

The body and the cover undergo a protection process including:

-Metallic sandblasting to achieve a roughness value not higher than 2.5 SA;

-Electric heating in the oven to reach a temperature of 220°C;

-Painting with fluidized bed technology of the preheated components using a floating epoxy powder. The above mentioned is the only possible process able to guarantee a minimum uniform thickness of 250 microns on the whole internal and external surface (higher thickness on request).

The powder we use is the FBE worldwide certified for potable water use.

ACCESSORIES

Anti freezing device

Every valve is provided with a 3/8" G threaded outlet, which can be used as an anti freezing device simply replacing the tap with a drainage cock discharging directly into the tank. During the winter season, when the temperature drops consistently, the partial opening of the drainage cock will create a flow rate inside the valve avoiding frost with consequent break.



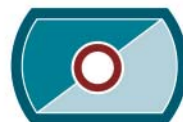

Typ ATHENA

FLOAT VALVE

PN 16, with balance single seat

Installation

-The valve is usually installed inside the tank even though in some cases it can be placed outside as from recent solutions (please see page nr. 7).

-Make sure that the supply pipe has the flanges drilled according to the requested PN, and that Athena is positioned in a horizontal position and properly fixed and sustained.

-Gate valves have to be installed to allow maintenance operations.

-Position the valve in a place easy to be reached and wide enough for maintenance and control purposes.

-Observe the overflow level and make sure that the outlet flange is always above it to avoid backflow.

-Before installing ATHENA proceed with an accurate pipe cleaning to prevent debris, stones or dirt from damaging its internal components. Shouldn't that be possible we strongly recommend to install a filter upstream.

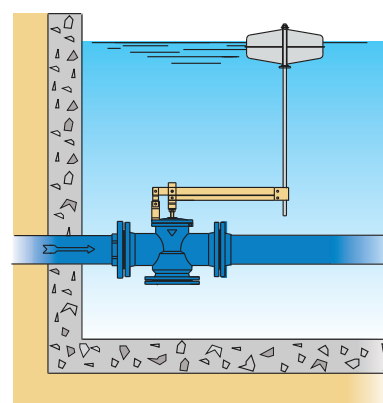
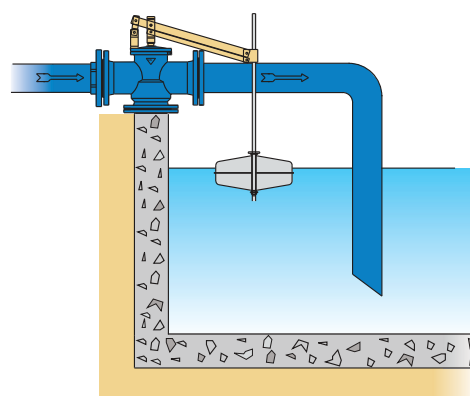
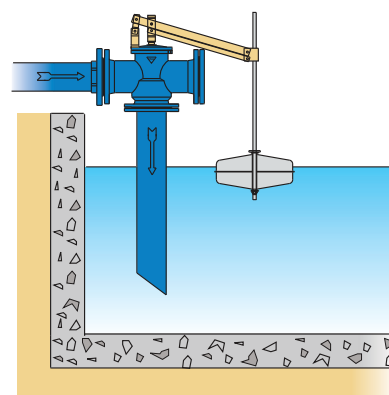

- In case of static pressure above 9 bar we strongly recommend to use a spring loaded PRV (our model VRCD) to reduce and maintain 7/8 bar acting on ATHENA.

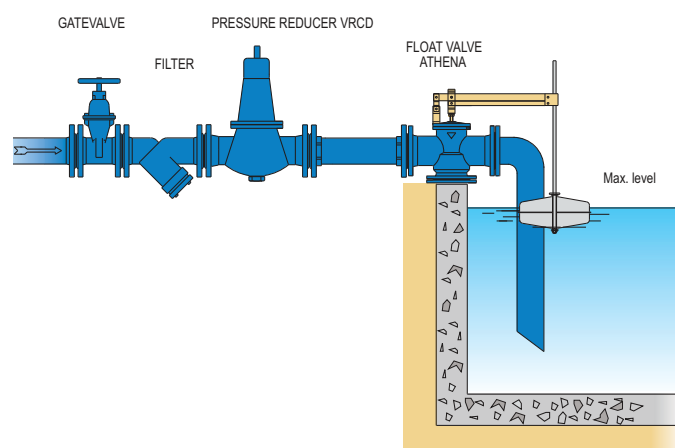

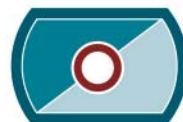

Typ ATHENA

FLOAT VALVE

PN 16, with balance single seat

ADDITIONAL FEATURES

Maximum - minimum level regulation control.

Float valves are usually designed to maintain a fixed water level inside the tank, despite that in some cases it is advisable to drain part of it to avoid moulds thanks to a proper air recirculation.

In the picture below is explained how to obtain the regulation of the maximum - minimum level inside the tank using Athena;

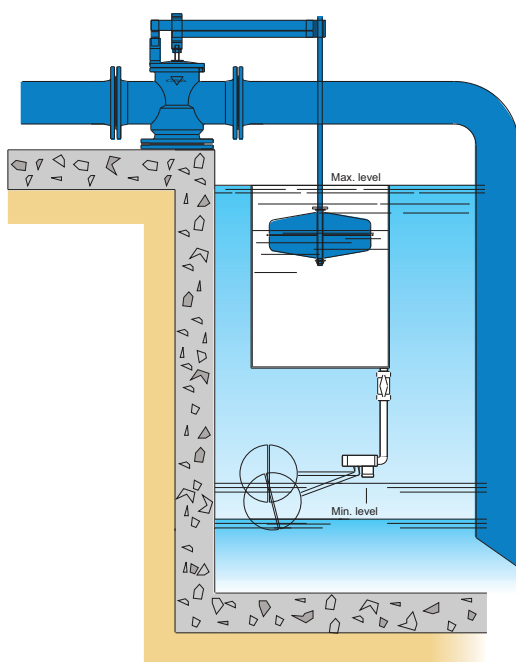

The KIT is composed of:

- a container in stainless steel or plastic, large enough to house the float, which is placed inside the tank having the top as the maximum level threshold;
- a float valve in brass DN 1"/ 1 1/2" which, by means of a galvanized pipe or in stainless steel, will have to be placed to set the minimum level as from the picture on the left.*

Thanks to this solution the main valve will discharge water as soon as the preset minimum level of the tank has been reached. ATHENA will cut off the supply only when water, coming from the tank inside the container, will push the float upwards closing the obturator.

Minimum level regulation

ATHENA can also be used the other way around. That is done simply by removing the smaller rod and by rotating the cover with an angle of 90°, with the result of interrupting the supply in correspondence of the minimum level to reopen again as soon as it goes up.

External levers and pivots

According to recent specifications valves tend to be more and more installed in places easy to access, keeping the tank as something strictly separated from the environment. In the picture on the right we will show you how to obtain the water level regulation and control having ATHENA positioned directly on the ground outside of the tank.

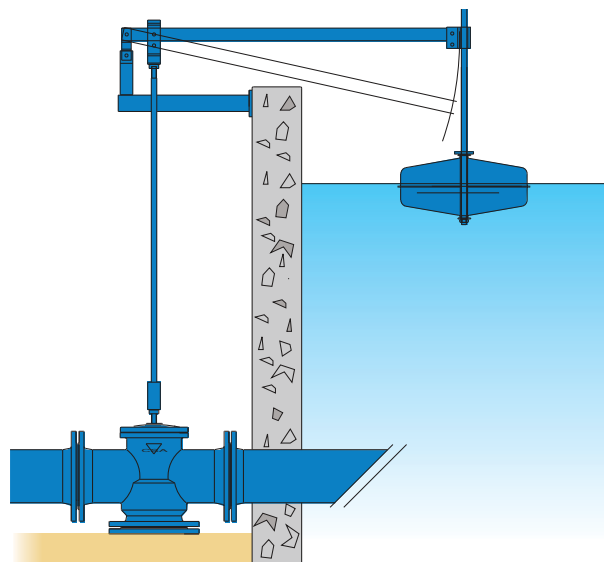

*We will remain at your complete disposal to inform you about our customers most important experiences.